

POST PROTECTOR

Handle-It™ Post Protectors are designed as an economical way to protect racking from manually transferred materials. Installation is easy and can be used in many rack protecting applications. Bright yellow powder coat paint makes the post protector easily seen.

Features and Benefits

- Handle-It™ Post Protectors help prevent damage to rack uprights, shelving uprights, partitions and many other factory and warehouse structures.
- These heavy steel protectors provide a low cost method of reducing damage to expensive equipment and protecting personnel from falling rack structures hit by moving vehicles.
- Handle-It™ Post Protectors wrap around the 3" column face vertical member to be protected, closely fitting, yet protecting, the upright from damage from collisions with forklifts or other moving vehicles.
- These heavy duty ¼" thick steel protectors are easily mounted by securing to the concrete floor using four ½" diameter wedge anchors (supplied as optional purchase).
- A variety of standard heights are available (12", 18" & 24") with custom heights and openings also available on special order
- Handle-It™ Post Protectors are painted in safety yellow hard glossy finish for a durable attractive appearance.

1-800-236-1080
www.miequipment.com



Post Protector

Custom sizes are available, including seismic applications.

Guarantee and Warranty

Personal and professional customer service is offered on all Handle-It™ Post Protectors. Our Post Protection carries a one-year limited warranty on all materials and workmanship.

POST PROTECTOR DIMENSIONS

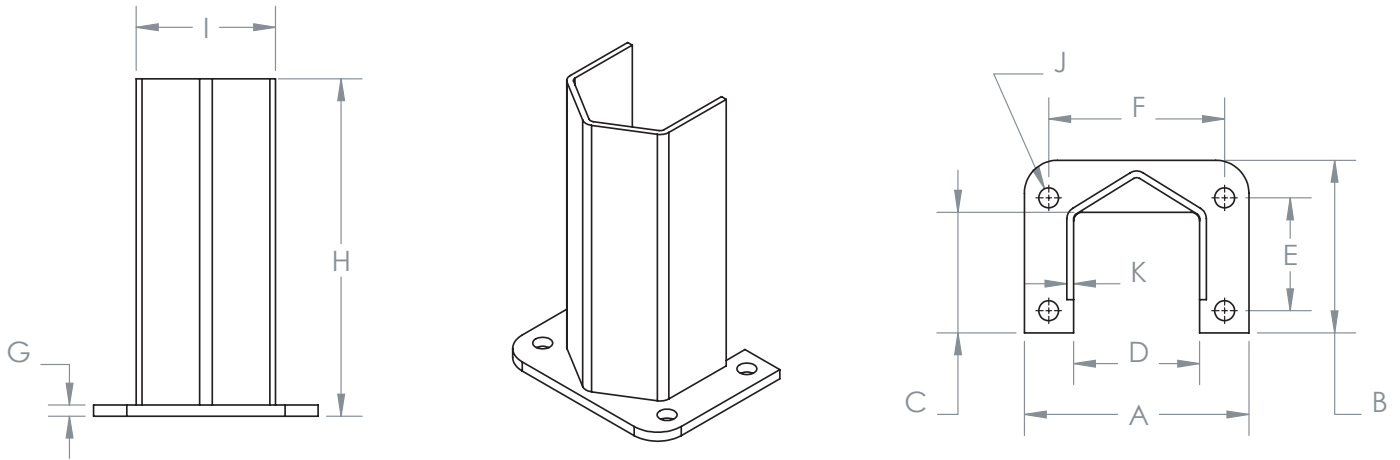

Model	A Overall Width	B Overall Length	C Inside Length	D Inside Width	E Side Hole to Hole	F Front Hole to Hole	G Base Plate Thickness	H Overall Height	I Guard Width	J Hole Diameter	K Guard Thickness
P12-4.5	8	6 1/8	4 1/2	4 1/2	4	6 1/4	3/8	12	5	3/4	1/4
P18-4.5	8	6 1/8	4 1/2	4 1/2	4	6 1/4	3/8	18	5	3/4	1/4
P24-4.5	8	6 1/8	4 1/2	4 1/2	4	6 1/4	3/8	24	5	3/4	1/4
P12-6	9 1/2	6 1/8	4 1/2	6	4	7 3/4	3/8	12	6 1/2	3/4	1/4
P18-6	9 1/2	6 1/8	4 1/2	6	4	7 3/4	3/8	18	6 1/2	3/4	1/4
P24-6	9 1/2	6 1/8	4 1/2	6	4	7 3/4	3/8	24	6 1/2	3/4	1/4
P12-8	12	6 1/8	4 1/2	8 1/2	4	10 1/4	3/8	12	9	3/4	1/4
P18-8	12	6 1/8	4 1/2	8 1/2	4	10 1/4	3/8	18	9	3/4	1/4
P24-8	12	6 1/8	4 1/2	8 1/2	4	10 1/4	3/8	24	9	3/4	1/4

Post Protector Selection Guide

In order to select the correct size:

- Measure across foot plate of rack application
- Select desired width (refer to column D) that best suits foot plate
- Select desired height (refer to column H) for needed protection

Custom protection is our specialty. If your requirements are not listed in the above specifications, please contact us. Our design team will develop a quick economical solution to your protection needs.