

RH Electric Wire Rope Hoists

Harrington RH wire rope hoists are designed and built for today's heavy-duty wire rope hoist applications including fabricating, die handling, paper mill and production line work. State-of-the-art design features and construction make the RH extremely durable, highly reliable and very low maintenance for years of trouble free service.

The RH includes features that are expensive options on competitive hoists to include standard electromechanical load limiting device, fan-cooled motors and rubber trolley bumpers. Maintenance and failures associated with disc type brakes are eliminated with our revolutionary conical rotor brake system. The sealed hoist electrical enclosure means airborne grit and contamination will not penetrate the hoist to cause premature failure of electrical components. A truly unique wire rope guide prevents improper rope alignment on the grooved drum.

The RH's design is maintenance friendly. Examples are a hinged electrical panel and external upper/lower limit switches to minimize hoist downtime and expense.

High quality paint is electrostatically applied for corrosion resistance in harsh environments

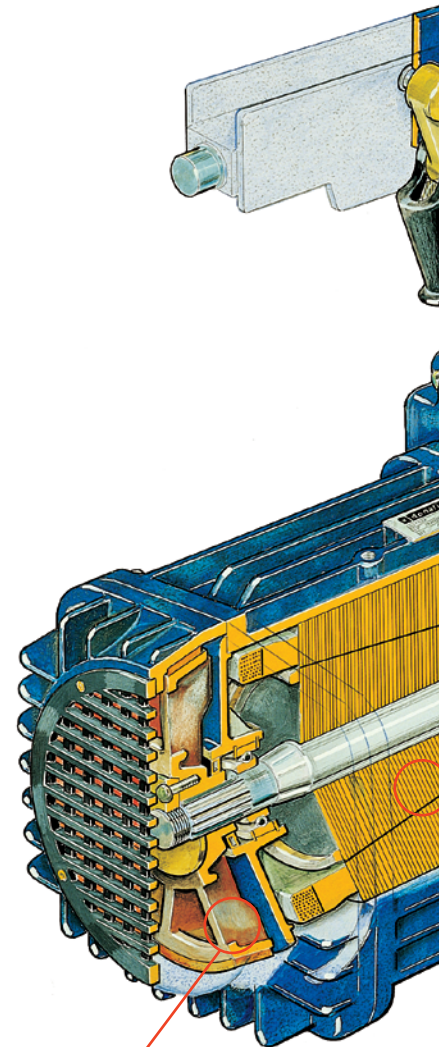

Conical rotor brake is fan cooled to ensure long life

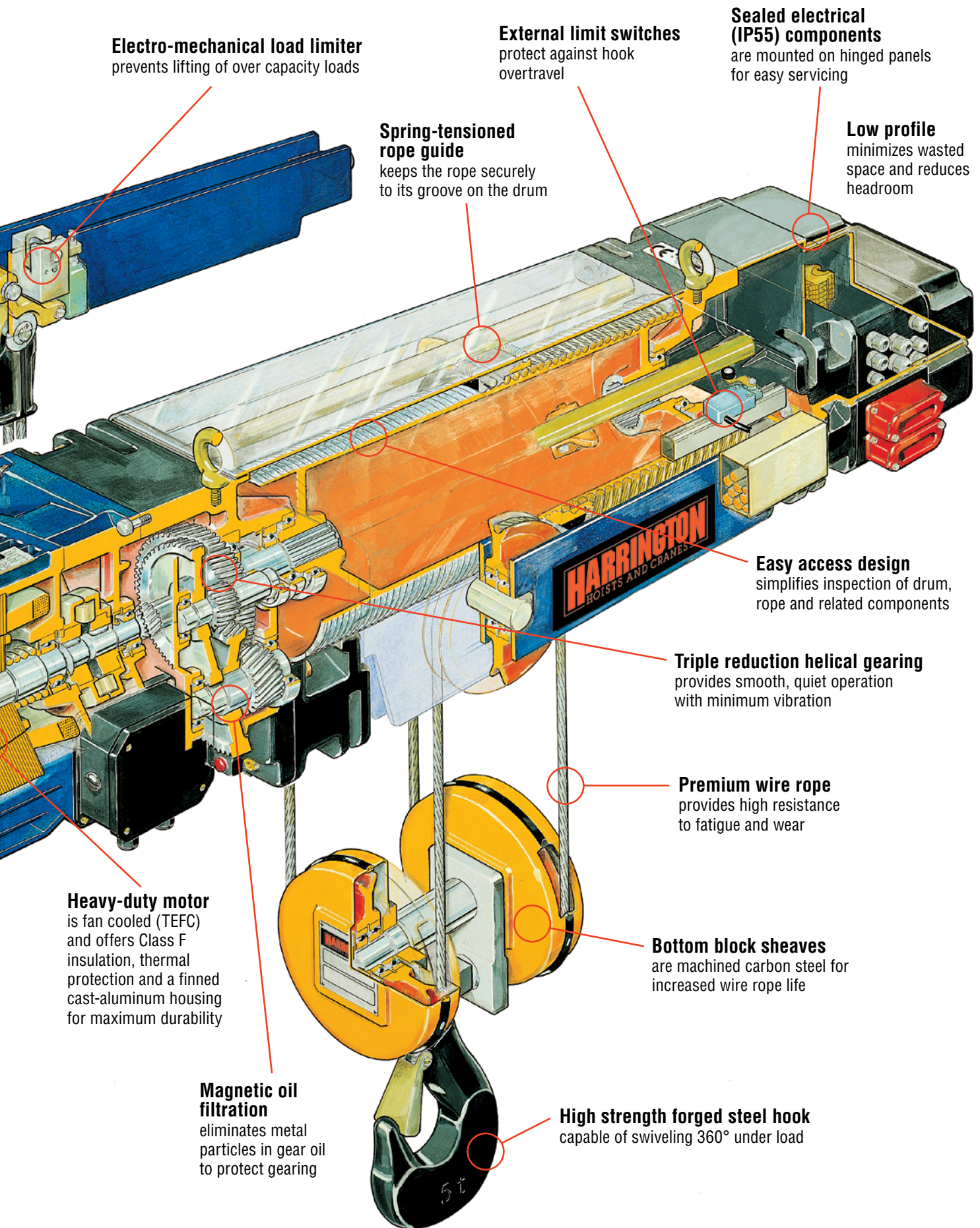

Electro-mechanical load limiter
prevents lifting of over capacity loads

External limit switches
protect against hook
overtravel

**Sealed electrical
(IP55) components**
are mounted on hinged panels
for easy servicing

**Spring-tensioned
rope guide**
keeps the rope securely
to its groove on the drum

Low profile
minimizes wasted
space and reduces
headroom

Easy access design
simplifies inspection of drum,
rope and related components

Triple reduction helical gearing
provides smooth, quiet operation
with minimum vibration

Premium wire rope
provides high resistance
to fatigue and wear

Bottom block sheaves
are machined carbon steel for
increased wire rope life

High strength forged steel hook
capable of swiveling 360° under load

Heavy-duty motor
is fan cooled (TEFC)
and offers Class F
insulation, thermal
protection and a finned
cast-aluminum housing
for maximum durability

**Magnetic oil
filtration**
eliminates metal
particles in gear oil
to protect gearing

RH Electric Wire Rope Hoists and Trolleys

Standard Specifications

Capacities (Tons):	2, 3, 5, 7 1/2, 10, 15, 20
Lift Range (feet):	20' to 105'
Lifting Speeds (ft/min):	16, 24, 32, 48
Dual Lifting Speeds (ft/min):	16/5, 24/8, 32/10, 48/16
Trolley Travel Speeds (ft/min):	40, 64, 80
Dual Trolley Travel Speeds (ft/min):	64/16, 80/20
Supply Voltages:	230-3-60, 460-3-60
Control Voltage:	110VAC
Reeving:	4/1 (four-part single reeved) or 2/1 (two-part single reeved)
Configurations:	<ul style="list-style-type: none">• Deck/base mounted or lug suspended hoists• Standard or ultra-low headroom trolley hoists

Note: Other capacities, speeds, lifts and voltages available — consult factory. Refer to pages 2 and 3 for more detailed standard features.

Many Trolley Benefits from More Standard Features

Electric Trolley Brake

- Provides positive stopping power and ultimate load control during loading and unloading.

Rubber Trolley Bumpers

- Bumpers are standard equipment.
- Bumpers reduce mechanical impact against trolley stops and are required for trolley hoist installation on overhead bridge cranes.

Heavy-Duty Trolley Drive

- Fan-cooled TEFC drive motor provides long, trouble-free service.
- IP55-rated, suitable for outdoor service and adds extra protection for indoor applications.
- Helical gear drives in oil bath provides cool, quiet and smooth operation.
- Trolley motor design provides smooth acceleration.

Dual-Side Trolley Drive

- Two driven wheels offer better traction for improved operator control.
- Driven wheels on opposite sides of the trolley provide smoother operation with less racking and skewing.

Extended Wheelbase Design

- Larger wheelbase than competitive units offers more stable travel.
- Provides better load distribution over the beam to reduce beam loading.

Dual Tread Wheels With Gear Guards

- Flat and tapered tread section is ideal for S or W beams.
- Ensures smooth tracking on wide flange beams common in industry.
- Gear guards protect gear ring and flange, as well as personnel.

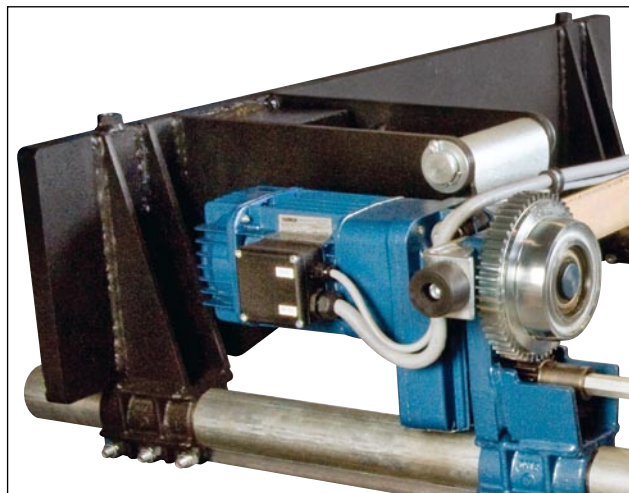

Deck/Base Mounted or Lug Suspended Hoists

For permanent installation or double-girder trolley applications, the Harrington deck/base mounted or lug suspended hoists are ideal for heavy-duty service.

- Modular body construction suitable for all mounting configurations.
- Single-axis or in-line design with motor, gearbox and drum sharing the same axis results in a low-profile, low-headroom hoist.
- For features and standard specifications, refer to pages 2, 3 & 4.
- For detailed specifications and dimensions, refer to Harrington's separate publication entitled "Electric Wire Rope Hoists Technical Manual."

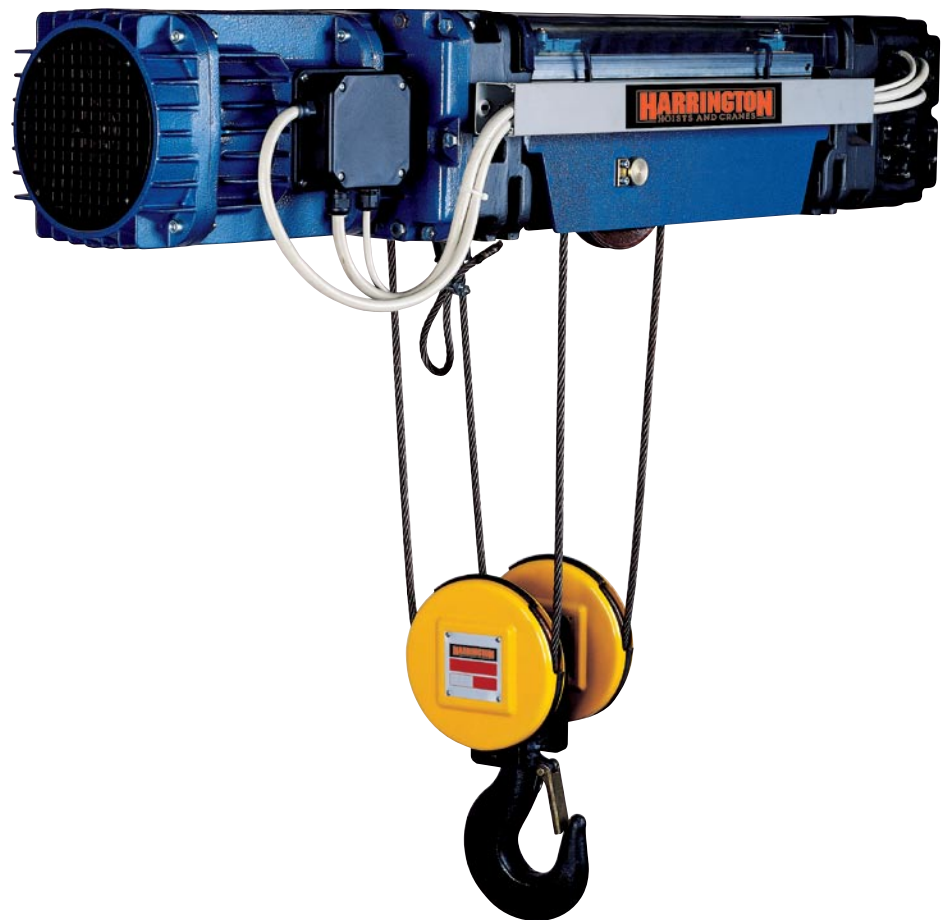

Options

- Universal eye-bolt kit suitable for all mounting configurations
- Pendant
- Pendant cord
- Power supply cord

Standard Headroom Trolley Hoists

For general use on bridge, gantry or jib cranes, as well as monorails, this standard Harrington monorail style trolley hoist combines versatility and performance.

- Available in any combination of single or dual speed models in a variety of speed combinations.
- Hoist oriented parallel to beam.
- For features and standard specifications, refer to pages 2, 3 & 4.
- For detailed specifications and dimensions, refer to Harrington's separate publication entitled "Electric Wire Rope Hoists Technical Manual."

Options

- Pendant
- Pendant cord
- Power supply cord
- Trolley travel limit switch

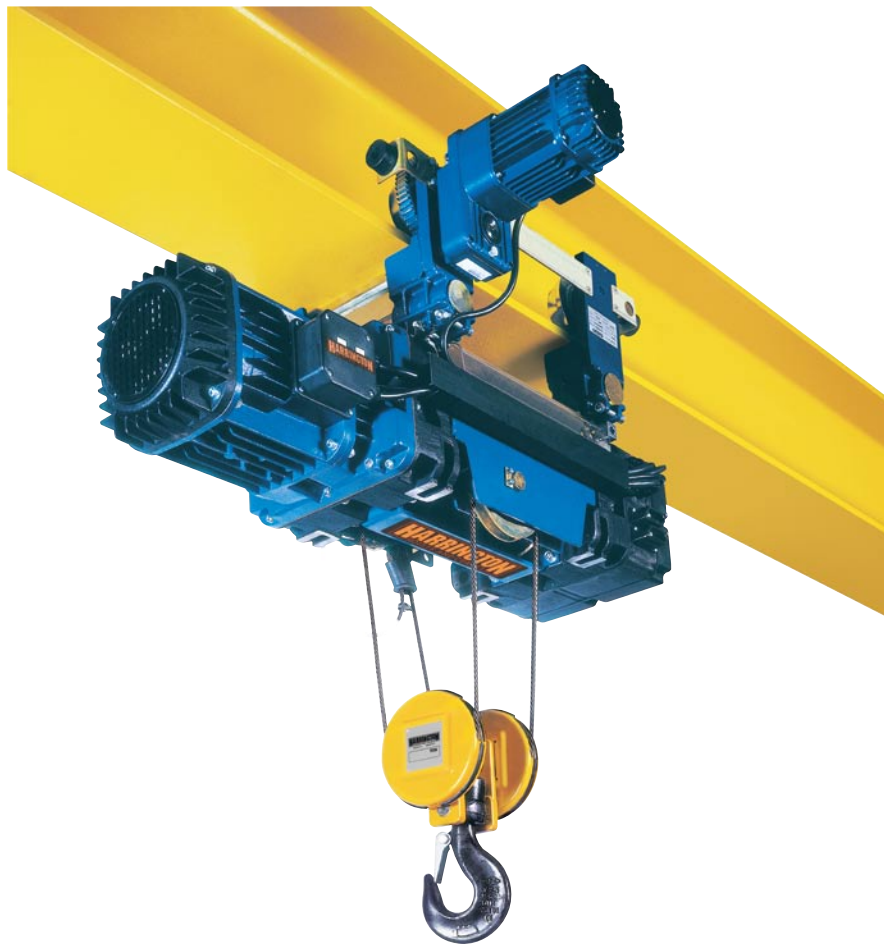

Ultra-Low Headroom Trolley Hoists

The Harrington Ultra-Low Headroom Trolley Hoist is designed for monorail and crane applications where minimum headroom is essential.

- The hoist body is parallel mounted beside the beam for extremely low headroom.
- A weight is mounted opposite the hoist to balance the unit on the monorail.
- For features and standard specifications, refer to pages 2, 3 & 4.
- For detailed specifications and dimensions, refer to Harrington's separate publication entitled "Electric Wire Rope Hoists Technical Manual."

Options

- Pendant
- Pendant cord
- Power supply cord
- Trolley travel limit switch



Deck/Base Mounted or Lug Suspended Hoists Specifications

Capacity (Tons)	Product Code	Lift (ft)	Lifting Speed (ft/min)		Reeving (parts/ reeving)	Rope** (mm- spec.)	Single Speed Motor 3 Phase 60Hz			Dual Speed Motor 3 Phase 60Hz			Net Weight (lbs)
			Single Speed	Dual Speed			Output (Hp)	Rated Current (amps)		Output (Hp)	Rated Current (amps)		
								@460V	@230V		@460V	@230V	
2	RH02D-20①4C-②	20	16	16/5	4/1	7-B	4.8	7.7	15.4	4.8/1.6	7.7/6.3	15.4/12.5	331
	RH02D-29①4C-②	29											375
	RH02D-20①4D-②	20	24	24/8									331
	RH02D-29①4D-②	29			375								
	RH02D-39①3A-②	39	32	32/10	2/1	7-A							311
	RH02D-79①3A-②	79				7-A*							353
3	RH03D-20①4C-②	20	16	16/5	4/1	7-A	4.8	7.7	15.4	4.8/1.6	7.7/6.3	15.4/12.5	331
	RH03D-29①4C-②	29											375
	RH03D-23①4H-②	23	24	24/8									9-B
	RH03D-33①4H-②	33			518								
	RH03D-46①3E-②	46	32	32/10	2/1	9-A							430
	RH03D-85①3E-②	85				9-A*							474
5	RH05D-23①4G-②	23	16	16/5	4/1	9-A	8.0	11.5	23.0	8.0/2.7	11.5/9.6	23.0/19.0	452
	RH05D-33①4G-②	33											518
	RH05D-23①4M-②	23	24	24/8									13-B
	RH05D-33①4M-②	33			1378								
	RH05D-46①4J-②	46	32	32/10	2/1	13-A							1080
	RH05D-92①4J-②	92				13-A*							1246
	RH05D-52①4P-②	52				16-B							1962
	RH05D-X5①4P-②	105	48	48/16	16-B*	2227							
7 1/2	RH08D-23①4L-②	23	16	16/5	4/1	13-M	16.1	21.0	42.0	16.1/5.4	23.0/17.3	46.0/34.5	1190
	RH08D-33①4L-②	33											1378
	RH08D-23①3M-②	23	24	24/8									13-B
	RH08D-33①3M-②	33			1378								
	RH08D-52①4N-②	52	32	32/10	2/1	16-A							1962
	RH08D-X5①4N-②	105				16-A*							2227
10	RH10D-23①4L-②	23	16	16/5	4/1	13-A	16.1	21.0	42.0	16.1/5.4	23.0/17.3	46.0/34.5	1190
	RH10D-33①4L-②	33											1378
	RH10D-26①4R-②	26	24	24/8									16-B
	RH10D-36①4R-②	36			2513								
	RH10D-52①3N-②	52	32	32/10	2/1	16-A							1962
	RH10D-X5①3N-②	105				16-A*							2227
15	RH15D-26①4Q-②	26	16	16/5	4/1	16-A	25.7	33.0	69.0	19.2/6.3	36.5/29.0	79.0/60.0	2205
	RH15D-36①4Q-②	36											2513
20	RH20D-26①3Q-②	26	16	16/5	4/1	16-A	25.7	33.0	69.0	19.2/6.3	36.5/29.0	79.0/60.0	2205
	RH20D-36①3Q-②	36											2513

- ① S = Single Speed Hoist
D = Dual Speed Hoist
- ② 2 = 230V – 3ph – 60Hz
4 = 460V – 3ph – 60Hz

*2/1 long lift hoists are fitted with anti-revolving rope.
 **Rope strengths are specified as: B = Base
 M = Medium
 A = High

Deck/Base Mounted or Lug Suspended Hoists Dimensions*

Capacity (Tons)	Product Code	H (in)	H1 (in)	H2 (in)	H3 (in)	I (in)	I1 (in)	L (in)	L1 (in)	N (in)	P (in)	Ø Q (in)	R (in)	S1 (in)	S2 (in)	S3 (in)	S4 (in)
2	RH02D-20①4C-②	25.6	16.5	9.1	13.6	9.8	20.3	12.6	8.3	18.3	10.0	8.9	48.6	3.9	10.4	5.9	0.6
	RH02D-29①4C-②						35.0						63.4	6.3	22.8		
	RH02D-20①4D-②						20.3						48.6	3.9	10.4		
	RH02D-29①4D-②						35.0						63.4	6.3	22.8		
	RH02D-39①3A-②	27.2	18.1		15.4	20.3	48.6	7.3	9.3	3.7	1.1						
	RH02D-79①3A-②					35.0	63.4	10.8	20.5								
3	RH03D-20①4C-②	25.6	16.5	9.1	13.6	9.8	20.3	12.6	8.3	18.3	10.0	8.9	48.6	3.9	10.4	5.9	0.6
	RH03D-29①4C-②						35.0						63.4	6.3	22.8		
	RH03D-23①4H-②	29.5	18.9	10.6	15.4	11.4	23.6	14.6	9.3	20.1	10.6	10.2	54.3	5.3	11.2	7.1	0.7
	RH03D-33①4H-②						39.4						70.1	8.3	24		
	RH03D-46①3E-②	32.3	21.7	10.6	17.5		23.6	14.6	9.3	20.1	10.6	10.2	54.3	8.7	11.0	3.9	1.2
	RH03D-85①3E-②						39.4						70.1	12.2	23.2		
5	RH05D-23①4G-②	29.5	18.9	10.6	15.4	11.4	23.6	14.6	9.3	20.1	10.6	10.2	54.3	5.3	11.2	7.1	0.7
	RH05D-33①4G-②						39.4						70.1	8.3	24.0		
	RH05D-23①4M-②	40.2	25.2	15.0	21.3	14.6	29.1	18.9	11.4	27.0	8.1	11.8	64.2	6.3	13.4	9.4	0.9
	RH05D-33①4M-②						49.6						84.6	9.4	30.7		
	RH05D-46①4J-②	42.9	28.0		23.4		29.1	18.9	11.4	27.0	8.1	11.8	64.2	10.4	13.6	5.1	1.6
	RH05D-92①4J-②						49.6						84.6	14.8	29.7		
	RH05D-52①4P-②	55.1	36.2	18.5	29.5	18.1	33.9	23.6	14.2	32.9	8.7	13.4	76.2	11.4	15.7	6.7	1.8
	RH05D-X5①4P-②						55.9						98.2	15.7	33.5		
7 1/2	RH08D-23①4L-②	40.2	25.2	15.0	21.3	14.6	29.1	18.9	11.4	27.0	8.1	11.8	64.2	6.3	13.4	9.4	0.9
	RH08D-33①4L-②						49.6						84.6	9.4	30.7		
	RH08D-23①3M-②						29.1						64.2	6.3	13.4		
	RH08D-33①3M-②						49.6						84.6	9.4	30.7		
	RH08D-52①4N-②	55.1	36.2	18.5	29.5	18.1	33.9	23.6	14.2	32.9	8.7	13.4	76.2	11.4	15.7	6.7	1.8
	RH08D-X5①4N-②						55.9						98.2	15.7	33.5		
10	RH10D-23①4L-②	40.2	25.2	15.0	21.3	14.6	29.1	18.9	11.4	27	8.1	11.8	64.2	6.3	13.4	9.4	0.9
	RH10D-33①4L-②						49.6						84.6	9.4	30.7		
	RH10D-26①4R-②	52.0	33.5	18.5	27.6	18.1	33.9	23.6	14.2	32.9	8.7	13.4	76.2	7.1	13	13.8	1.0
	RH10D-36①4R-②						55.9						98.2	8.7	33.5		
	RH10D-52①3N-②	55.1	36.2		29.5		33.9	23.6	14.2	32.9	8.7	13.4	76.2	11.4	15.7	6.7	1.8
	RH10D-X5①3N-②						55.9						98.2	15.7	33.5		
15	RH15D-26①4Q-②	52.0	33.5	18.5	27.6	18.1	33.9	23.6	14.2	32.9	8.7	13.4	76.2	7.1	13	13.8	1.0
	RH15D-36①4Q-②						55.9						98.2	8.7	33.5		
20	RH20D-26①3Q-②	52.0	33.5	18.5	27.6	18.1	33.9	23.6	14.2	32.9	8.7	13.4	76.2	7.1	13	13.8	1.0
	RH20D-36①3Q-②						55.9						98.2	8.7	33.5		

*See page 12 for Deck/Base Mounted or Lug Suspended eye bolt and attachment point dimensions.

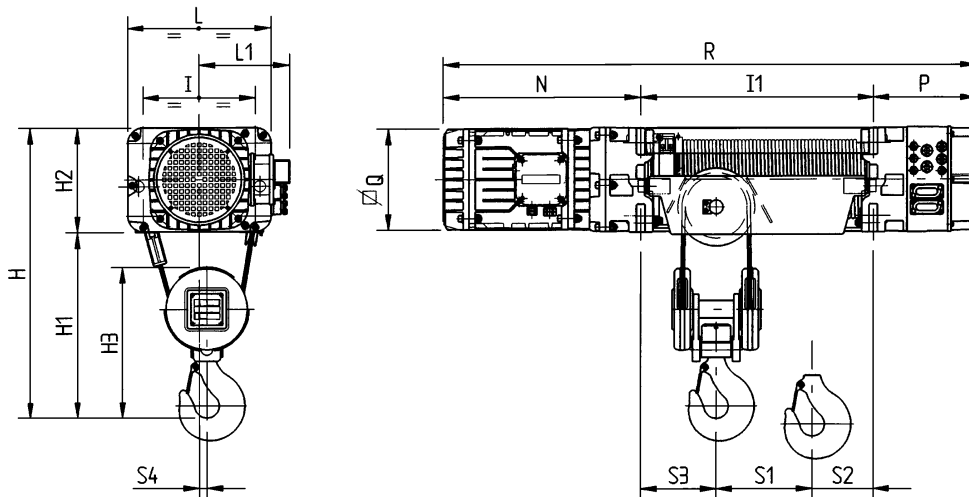

Standard Headroom Trolley Hoists Hoist Specifications

Capacity (Tons)	Product Code	Lift (ft)	Lifting Speed (ft/min)		Reeving (parts/ reeving)	Rope** (mm- spec.)	Single Speed Motor Lifting 3 Phase 60Hz			Dual Speed Motor Lifting 3 Phase 60Hz			Net Weight (lbs)
			Single Speed	Dual Speed			Output (Hp)	Rated Current (amps)		Output (Hp)	Rated Current (amps)		
								@460V	@230V		@460V	@230V	
2	RH02S-20①4C-②-③	20	16	16/5	4/1	7-B	4.8	7.7	15.4	4.8/1.6	7.7/6.3	15.4/12.5	529
	RH02S-29①4C-②-③	29		573									
	RH02S-20①4D-②-③	20	24	24/8									529
	RH02S-29①4D-②-③	29		573									
	RH02S-39①3A-②-③	39	32	32/10	2/1	7-A							509
	RH02S-79①3A-②-③	79				7-A*							551
3	RH03S-20①4C-②-③	20	16	16/5	4/1	7-A	4.8	7.7	15.4	4.8/1.6	7.7/6.3	15.4/12.5	529
	RH03S-29①4C-②-③	29		573									
	RH03S-23①4H-②-③	23	24	24/8									728
	RH03S-33①4H-②-③	33		794									
	RH03S-46①3E-②-③	46	32	32/10	2/1	9-A							617
	RH03S-85①3E-②-③	85				9-A*							672
5	RH05S-23①4G-②-③	23	16	16/5	4/1	9-A	8.0	11.5	23.0	8.0/2.7	11.5/9.6	23.0/19.0	728
	RH05S-33①4G-②-③	33		794									
	RH05S-23①4M-②-③	23	24	24/8									1918
	RH05S-33①4M-②-③	33		2083									
	RH05S-46①4J-②-③	46	32	32/10	2/1	13-A							1378
	RH05S-92①4J-②-③	92				13-A*							1543
	RH05S-52①4P-②-③	52	48	48/16	2/1	16-B	2690						
	RH05S-X5①4P-②-③	105				16-B*	2954						
7 1/2	RH08S-23①4L-②-③	23	16	16/5	4/1	13-M	16.1	21.0	42.0	16.1/5.4	23.0/17.3	46.0/34.5	1918
	RH08S-33①4L-②-③	33		2083									
	RH08S-23①3M-②-③	23	24	24/8									1918
	RH08S-33①3M-②-③	33		2083									
	RH08S-52①4N-②-③	52	32	32/10	2/1	16-A							2690
	RH08S-X5①4N-②-③	105				16-A*							2954
10	RH10S-23①4L-②-③	23	16	16/5	4/1	13-A	16.1	21.0	42.0	16.1/5.4	23.0/17.3	46.0/34.5	1918
	RH10S-33①4L-②-③	33		2083									
	RH10S-26①4R-②-③	26	24	24/8									3351
	RH10S-36①4R-②-③	36		3660									
	RH10S-52①3N-②-③	52	32	32/10	2/1	16-A							2690
	RH10S-X5①3N-②-③	105				16-A*							2954
15	RH15S-26①4Q-②-③	26	16	16/5	4/1	16-A	25.7	33.0	69.0	19.2/6.3	36.5/29.0	79.0/60.0	3351
	RH15S-36①4Q-②-③	36		3660									
20	RH20S-26①3Q-②-③	26	16	16/5	4/1	16-A	25.7	33.0	69.0	19.2/6.3	36.5/29.0	79.0/60.0	3351
	RH20S-36①3Q-②-③	36		3660									

- ① S = Single Speed Hoist
D = Dual Speed Hoist
- ② 2 = 230V – 3ph – 60Hz
4 = 460V – 3ph – 60Hz
- ③ Traversing Speed:
F = 40 ft/min
G = 64 ft/min
H = 80 ft/min
V = 64/16 ft/min
W = 80/20 ft/min

*2/1 long lift hoists are fitted with anti-revolving rope.
 **Rope strengths are specified as: B = Base
 M = Medium
 A = High

Standard Headroom Trolley Hoists Trolley Specifications

Capacity (Tons)	Product Code	Standard Flange Range B* (in)	Traversing Motors								
			Single Speed 40 ft/min			Single Speed 64 and 80 ft/min			Dual Speed 64/16 and 80/20 ft/min		
			Output (Hp)	Rated Current (amps)		Output (Hp)	Rated Current (amps)		Output (Hp)	Rated Current (amps)	
				@460V	@230V		@460V	@230V		@460V	@230V
2	RH02S-20①4C-②-③	3.54 to 11.02	0.32	1.1	2.2	0.6	1.1	3.0	0.6/0.13	1.3/1.1	2.5/2.2
	RH02S-29①4C-②-③										
	RH02S-20①4D-②-③										
	RH02S-29①4D-②-③										
	RH02S-39①3A-②-③										
RH02S-79①3A-②-③											
3	RH03S-20①4C-②-③	3.54 to 11.02	0.32	1.1	2.2	0.6	1.1	3.0	0.6/0.13	1.3/1.1	2.5/2.2
	RH03S-29①4C-②-③	4.69 to 11.02									
	RH03S-23①4H-②-③										
	RH03S-33①4H-②-③										
	RH03S-46①3E-②-③	3.54 to 11.02									
RH03S-85①3E-②-③											
5	RH05S-23①4G-②-③	4.69 to 11.02	0.32	1.1	2.2	0.6	1.1	3.0	0.6/0.13	1.3/1.1	2.5/2.2
	RH05S-33①4G-②-③										
	RH05S-23①4M-②-③	5.31 to 11.02	0.5			0.9	1.5	4.4	0.9/0.2	2.1/1.1	4.2/2.2
	RH05S-33①4M-②-③										
	RH05S-46①4J-②-③	4.69 to 11.02	0.32			0.6	1.1	3.0	0.6/0.13	1.3/1.1	2.5/2.2
	RH05S-92①4J-②-③										
	RH05S-52①4P-②-③	5.31 to 11.02	0.5			0.9	1.5	4.4	0.9/0.2	2.1/1.1	4.2/2.2
RH05S-X5①4P-②-③											
7 1/2	RH08S-23①4L-②-③	5.31 to 11.02	0.5	1.1	2.2	0.9	1.5	4.4	0.9/0.2	2.1/1.1	4.2/2.2
	RH08S-33①4L-②-③										
	RH08S-23①3M-②-③										
	RH08S-33①3M-②-③										
	RH08S-52①4N-②-③										
RH08S-X5①4N-②-③											
10	RH10S-23①4L-②-③	5.31 to 11.02	0.5	1.1	2.2	0.9	1.5	4.4	0.9/0.2	2.1/1.1	4.2/2.2
	RH10S-33①4L-②-③										
	RH10S-26①4R-②-③	6.69 to 11.02									
	RH10S-36①4R-②-③										
	RH10S-52①3N-②-③	5.31 to 11.02									
RH10S-X5①3N-②-③											
15**	RH15S-26①4Q-②-③	6.69 to 11.02	0.5 x 2	1.1 x 2	2.2 x 2	0.9 x 2	1.5 x 2	4.4 x 2	0.9/0.2 x 2	2.1/1.1 x 2	4.2/2.2 x 2
	RH15S-36①4Q-②-③										
20**	RH20S-26①3Q-②-③	6.69 to 11.02	0.5 x 2	1.1 x 2	2.2 x 2	0.9 x 2	1.5 x 2	4.4 x 2	0.9/0.2 x 2	2.1/1.1 x 2	4.2/2.2 x 2
	RH20S-36①3Q-②-③										

*Optional wider flange ranges available. Wider flange range is the standard lower value to 15.75 inch.
Example: Wider flange range for 2 Ton trolley hoists is 3.54 to 15.75 inches.

**15 and 20 Ton models are equipped with 2 trolley motors.

Standard Headroom Trolley Hoists Dimensions

Capacity (Tons)	Product Code	C (in)	C1 (in)	C2 (in)	D (in)	D1 (in)	E (in)	E1 (in)	E2 (in)	I1 (in)	ØR (in)	S1 (in)	S2 (in)	S3 (in)	
2	RH02S-20①4C-②-③	6.7	3.3	11.6	2.4	14.6	32.7	5.9	7.1	20.3	3.94	3.9	10.4	5.9	
	RH02S-29①4C-②-③									35		6.3	22.8		
	RH02S-20①4D-②-③									20.3		3.9	10.4		
	RH02S-29①4D-②-③									35.0		6.3	22.8		
	RH02S-39①3A-②-③									20.3		7.3	9.3		
	RH02S-79①3A-②-③						35	10.8	20.5	3.7					
3	RH03S-20①4C-②-③	6.7	3.3	11.6	2.4	14.6	32.7	5.9	7.1	20.3	3.94	3.9	10.4	5.9	
	RH03S-29①4C-②-③									35.0		6.3	22.8		
	RH03S-23①4H-②-③	8.1	2.6	12	2.6	14.8	37.4	6.2	7.7	23.6	4.92	5.3	11.2	7.1	
	RH03S-33①4H-②-③									39.4		8.3	24		
	RH03S-46①3E-②-③	6.7	3.9	13.4	2.4	14.6	39.4	5.9	7.1	23.6	3.94	8.7	11.0	3.9	
	RH03S-85①3E-②-③									39.4		12.2	23.2		
5	RH05S-23①4G-②-③	8.1	2.6	12	2.6	14.8	37.4	6.2	7.7	23.6	4.92	5.3	11.2	7.1	
	RH05S-33①4G-②-③									39.4		8.3	24		
	RH05S-23①4M-②-③	11.4	-3.3	15.6	3.5	15.7	50.8	9.8	10.4	29.1	7.87	6.3	13.4	9.4	
	RH05S-33①4M-②-③									49.6		9.4	30.7		
	RH05S-46①4J-②-③	8.1	0	18.9	2.7	14.8	50.8	6.2	7.7	29.1	4.92	10.4	13.6	5.1	
	RH05S-92①4J-②-③									49.6		14.8	29.7		
	RH05S-52①4P-②-③	11.4	-2.8	21.5	3.5	15.7	65.7	9.8	10.4	33.9	7.87	11.4	15.7	6.7	
	RH05S-X5①4P-②-③									55.9		15.7	33.5		
7 1/2	RH08S-23①4L-②-③	11.4	-3.3	15.6	3.5	15.7	50.8	9.8	10.4	29.1	7.87	6.3	13.4	9.4	
	RH08S-33①4L-②-③									49.6		9.4	30.7		
	RH08S-23①3M-②-③									29.1		6.3	13.4		
	RH08S-33①3M-②-③									49.6		9.4	30.7		
	RH08S-52①4N-②-③		-2.8	21.5	3.5	15.7	65.7	9.8	10.4	33.9		7.87	11.4	15.7	6.7
	RH08S-X5①4N-②-③									55.9			15.7	33.5	
10	RH10S-23①4L-②-③	11.4	-3.3	15.6	3.5	15.7	50.8	9.8	10.4	29.1	7.87	6.3	13.4	9.4	
	RH10S-33①4L-②-③									49.6		9.4	30.7		
	RH10S-26①4R-②-③	13.4	-4.7	19.5	3.9	16.1	63.8	12.2	12.0	33.9	9.84	7.1	13.0	13.8	
	RH10S-36①4R-②-③									55.9		8.7	33.5		
	RH10S-52①3N-②-③	11.4	-2.8	21.5	3.5	15.7	65.7	9.8	10.4	33.9	7.87	11.4	15.7	6.7	
	RH10S-X5①3N-②-③									55.9		15.7	33.5		
15*	RH15S-26①4Q-②-③	13.4	-4.7	19.5	3.9	16.1	63.8	12.2	12.0	33.9	9.84	7.1	13.0	13.8	
	RH15S-36①4Q-②-③									55.9		8.7	33.5		
20*	RH20S-26①3Q-②-③	13.4	-4.7	19.5	3.9	16.1	63.8	12.2	12.0	33.9	9.84	7.1	13.0	13.8	
	RH20S-36①3Q-②-③									55.9		8.7	33.5		

*15 and 20 Ton models are equipped with 2 trolley motors.

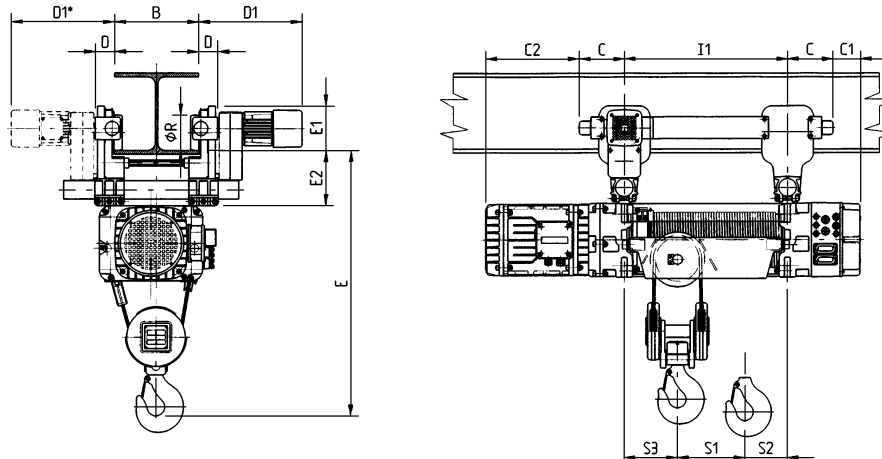

Note:
 ■ Standard headroom trolleys are suitable for use on S or W shaped beams.
 ■ Refer to page 7 for flange range dimension B

Ultra-Low Headroom Trolley Hoists Hoist Specifications

Capacity (Tons)	Product Code	Lift (ft)	Lifting Speed (ft/min)		Reeving (parts/ reeving)	Rope** (mm- spec.)	Single Speed Motor 3 Phase 60Hz			Dual Speed Motor 3 Phase 60Hz			Net Weight (lbs)													
			Single Speed	Dual Speed			Output (Hp)	Rated Current (amps)		Output (Hp)	Rated Current (amps)															
								@460V	@230V		@460V	@230V														
2	RH02U-20①4C-②-③	20	16	16/5	4/1	7-B	4.8	7.7	15.4	4.8/1.6	7.7/6.3	15.4/12.5	705													
	RH02U-29①4C-②-③	29											750													
	RH02U-20①4D-②-③	20	24	24/8									705													
	RH02U-29①4D-②-③	29											750													
	RH02U-39①3A-②-③	39	32	32/10	2/1	7-A							686													
	RH02U-79①3A-②-③	79				7-A*							728													
3	RH03U-20①4C-②-③	20	16	16/5	4/1	7-A	4.8	7.7	15.4	4.8/1.6	7.7/6.3	15.4/12.5	705													
	RH03U-29①4C-②-③	29											750													
	RH03U-23①4H-②-③	23	24	24/8									9-B	8.0	11.5	23.0	8.0/2.7	11.5/9.6	23.0/19.0	1036						
	RH03U-33①4H-②-③	33																		1102						
	RH03U-46①3E-②-③	46	32	32/10	2/1	9-A							893													
	RH03U-85①3E-②-③	85				9-A*							948													
5	RH05U-23①4G-②-③	23	16	16/5	4/1	9-A	8.0	11.5	23.0	8.0/2.7	11.5/9.6	23.0/19.0	1036													
	RH05U-33①4G-②-③	33											1102													
	RH05U-23①4M-②-③	23	24	24/8									13-B	16.1	21.0	42.0	16.1/5.4	23.0/17.3	46.0/34.5	2624						
	RH05U-33①4M-②-③	33																		2811						
	RH05U-46①4J-②-③	46	32	32/10	2/1	13-A							2017													
	RH05U-92①4J-②-③	92				13-A*							2183													
	RH05U-52①4P-②-③	52	48	48/16	16-B	25.7	33.0	69.0	19.2/6.3	36.5/29.0	79.0/60.0	3869														
	RH05U-X5①4P-②-③	105										16-B*	4244													
7 1/2	RH08U-23①4L-②-③	23	16	16/5	4/1							13-M	16.1	21.0	42.0	16.1/5.4	23.0/17.3	46.0/34.5	2624							
	RH08U-33①4L-②-③	33																	2811							
	RH08U-23①3M-②-③	23	24	24/8															13-B	25.7	33.0	69.0	19.2/6.3	36.5/29.0	79.0/60.0	2624
	RH08U-33①3M-②-③	33																								2811
	RH08U-52①4N-②-③	52	32	32/10	2/1	16-A	3869																			
	RH08U-X5①4N-②-③	105				16-A*	4244																			
10	RH10U-23①4L-②-③	23	16	16/5	4/1	13-A	16.1	21.0	42.0	16.1/5.4	23.0/17.3	46.0/34.5	2624													
	RH10U-33①4L-②-③	33											2811													
	RH10U-26①4R-②-③	26	24	24/8									16-B	25.7	33.0	69.0	19.2/6.3	36.5/29.0	79.0/60.0	4707						
	RH10U-36①4R-②-③	36																		5170						
	RH10U-52①3N-②-③	52	32	32/10	2/1	16-A							3869													
	RH10U-X5①3N-②-③	105				16-A*							4244													
15	RH15U-26①4Q-②-③	26	16	16/5	4/1	16-A	25.7	33.0	69.0	19.2/6.3	36.5/29.0	79.0/60.0	4707													
	RH15U-36①4Q-②-③	36											5170													
20	RH20U-26①3Q-②-③	26	16	16/5	4/1	16-A	25.7	33.0	69.0	19.2/6.3	36.5/29.0	79.0/60.0	4707													
	RH20U-36①3Q-②-③	36											5170													

- ① S = Single Speed Hoist
D = Dual Speed Hoist
- ② 2 = 230V - 3ph - 60Hz
4 = 460V - 3ph - 60Hz
- ③ Traversing Speed:
F = 40 ft/min
G = 64 ft/min
H = 80 ft/min
V = 64/16 ft/min
W = 80/20 ft/min

*2/1 long lift hoists are fitted with anti-revolving rope.
 **Rope strengths are specified as: B = Base
 M = Medium
 A = High

Ultra-Low Headroom Trolley Hoists Trolley Specifications

Capacity (Tons)	Product Code	Standard Flange Width B (in)	Traversing Motors									
			Single Speed 40 ft/min			Single Speed 64 and 80 ft/min			Dual Speed 64/16 and 80/20 ft/min			
			Output (Hp)	Rated Current (amps)		Output (Hp)	Rated Current (amps)		Output (Hp)	Rated Current (amps)		
				@460V	@230V		@460V	@230V		@460V	@230V	
2	RH02U-20①4C-②-③	3.54 to 15.75	0.32	1.1	2.2	0.6	1.1	3.0	0.6/0.13	1.3/1.1	2.5/2.2	
	RH02U-29①4C-②-③											
	RH02U-20①4D-②-③											
	RH02U-29①4D-②-③											
	RH02U-39①3A-②-③											
	RH02U-79①3A-②-③											
3	RH03U-20①4C-②-③	3.54 to 15.75	0.32	1.1	2.2	0.6	1.1	3.0	0.6/0.13	1.3/1.1	2.5/2.2	
	RH03U-29①4C-②-③	4.69 to 15.75										
	RH03U-23①4H-②-③	3.54 to 15.75										
	RH03U-33①4H-②-③											
	RH03U-46①3E-②-③											
	RH03U-85①3E-②-③											
5	RH05U-23①4G-②-③	4.69 to 15.75	0.32	1.1	2.2	0.6	1.1	3.0	0.6/0.13	1.3/1.1	2.5/2.2	
	RH05U-33①4G-②-③	5.31 to 15.75	0.5			0.9	1.5	4.4	0.9/0.2	2.1/1.1	4.2/2.2	
	RH05U-23①4M-②-③		4.69 to 15.75			0.32	0.6	1.1	3.0	0.6/0.13	1.3/1.1	2.5/2.2
	RH05U-33①4M-②-③											
	RH05U-46①4J-②-③	5.31 to 15.75	0.5			0.9	1.5	4.4	0.9/0.2	2.1/1.1	4.2/2.2	
	RH05U-92①4J-②-③											
	RH05U-52①4P-②-③											
RH05U-X5①4P-②-③												
7 1/2	RH08U-23①4L-②-③	5.31 to 15.75	0.5	1.1	2.2	0.9	1.5	4.4	0.9/0.2	2.1/1.1	4.2/2.2	
	RH08U-33①4L-②-③											
	RH08U-23①3M-②-③											
	RH08U-33①3M-②-③											
	RH08U-52①4N-②-③											
	RH08U-X5①4N-②-③											
10	RH10U-23①4L-②-③	5.31 to 15.75	0.5	1.1	2.2	0.9	1.5	4.4	0.9/0.2	2.1/1.1	4.2/2.2	
	RH10U-33①4L-②-③	6.69 to 15.75										
	RH10U-26①4R-②-③											
	RH10U-36①4R-②-③											
	RH10U-52①3N-②-③	5.31 to 15.75										
	RH10U-X5①3N-②-③											
15*	RH15U-26①4Q-②-③	6.69 to 15.75	0.5 x 2	1.1 x 2	2.2 x 2	0.9 x 2	1.5 x 2	4.4 x 2	0.9/0.2 x 2	2.1/1.1 x 2	4.2/2.2 x 2	
	RH15U-36①4Q-②-③											
20*	RH20U-26①3Q-②-③	6.69 to 15.75	0.5 x 2	1.1 x 2	2.2 x 2	0.9 x 2	1.5 x 2	4.4 x 2	0.9/0.2 x 2	2.1/1.1 x 2	4.2/2.2 x 2	
	RH20U-36①3Q-②-③											

*15 and 20 Ton models are equipped with 2 trolley motors.

10

Ultra-Low Trolley Hoist Headroom

Hoist Code	Flange Range (in)	Headroom, E* (in)	Headroom, E for 6 inch Flange (in)
A or B	3.54 to 15.75	17.3 + (1.13 x T)	24.1
C or D	3.54 to 6.79	18.9	18.9
	6.80 to 15.75	11.1 + (1.15 x T)	
E or F	3.54 to 15.75	17.6 + (1.13 x T)	24.8
G or H	4.69 to 6.49	18.9	18.9
	6.50 to 15.75	10.9 + (1.23 x T)	

Hoist Code	Flange Range (in)	Headroom, E* (in)	Headroom, E for 6 inch Flange (in)
J or K	4.69 to 8.66	26.8	26.8
	8.67 to 15.75	16.2 + (1.22 x T)	
L or M	5.31 to 10.51	24.0	24.0
	10.52 to 15.75	11.4 + (1.20 x T)	
N or P	5.31 to 10.16	32.7	32.7
	10.17 to 15.75	20.5 + (1.20 x T)	
Q or R	6.69 to 11.81	31.1	31.1**
	11.82 to 15.75	24.0 + (0.60 x T)	

*T in formulas is the exact beam flange width in inches.

**Headroom value for 7 inch flange.

Ultra-Low Headroom Trolley Hoists Dimensions

Capacity (Tons)	Product Code	C (in)	C1 (in)	C2 (in)	D (in)	D1 (in)	D2 (in)	E1 (in)	E2 (in)	I1 (in)	ØR (in)	S1 (in)	S2 (in)	S3 (in)		
2	RH02U-20①4C-②-③	6.7	3.3	11.6	17.3	9.1	15.6	5.9	7.1	20.3	3.94	3.9	10.4	5.9		
	RH02U-29①4C-②-③						14.4					35.0	6.3		22.8	
	RH02U-20①4D-②-③						15.6					20.3	3.9		10.4	
	RH02U-29①4D-②-③						14.4					35.0	6.3		22.8	
	RH02U-39①3A-②-③						15.6					20.3	7.3		9.3.0	
	RH02U-79①3A-②-③						14.4					35.0	10.8		20.5	
3	RH03U-20①4C-②-③	6.7	3.3	11.6	17.3	9.1	15.6	5.9	7.1	20.3	3.94	3.9	10.4	5.9		
	RH03U-29①4C-②-③	8.1	2.6	12	19.5	10.2	14.4	7.1	7.7	35.0	4.92	6.3	22.8	7.1		
	RH03U-23①4H-②-③						17.3			23.6		5.3	11.2			
	RH03U-33①4H-②-③						16.1			39.4		8.3	24			
	RH03U-46①3E-②-③	6.7	3.9	13.4	19.3	10.0	17.7	7.1	7.1	23.6	3.94	8.7	11.0	3.9		
	RH03U-85①3E-②-③	11.4	-3.3	15.6	24.6	13.2	16.5	10.2	10.4	39.4	7.87	12.2	23.2	9.4		
RH05U-23①4G-②-③	17.3						23.6			5.3		11.2				
RH05U-33①4G-②-③	8.1	0	18.9	23.8	12.4	16.1	11.8	7.7	39.4	4.92	8.3	24.0	5.1			
RH05U-23①4M-②-③						22.8			29.1		6.3	13.4				
RH05U-33①4M-②-③	11.4	-2.8	21.5	29.7	15.6	21.7	13.6	10.4	49.6	7.87	9.4	30.7	6.7			
RH05U-46①4J-②-③						24.0			29.1		10.4	13.6				
RH05U-92①4J-②-③	11.4	-2.8	21.5	29.7	15.6	22.8	10.4	10.4	49.6	7.87	14.8	29.7	9.4			
RH05U-52①4P-②-③						33.9			55.9		11.4	15.7				
RH05U-X5①4P-②-③	11.4	-3.3	15.6	24.6	13.2	22.8	10.2	10.4	10.4	7.87	7.87	15.7	33.5	9.4		
RH08U-23①4L-②-③												29.1	49.6		6.3	13.4
RH08U-33①4L-②-③												21.7	49.6		9.4	30.7
RH08U-23①3M-②-③												22.8	29.1		6.3	13.4
RH08U-33①3M-②-③												21.7	49.6		9.4	30.7
RH08U-52①4N-②-③												33.9	55.9		11.4	15.7
RH08U-X5①4N-②-③	11.4	-2.8	21.5	29.7	15.6	27.0	13.6	10.4	55.9	7.87	15.7	33.5	6.7			
RH10U-23①4L-②-③						22.8			29.1		6.3	13.4				
RH10U-33①4L-②-③	13.4	-4.7	19.5	30.1	15.9	21.7	13.6	12.0	49.6	9.84	9.4	30.7	13.8			
RH10U-26①4R-②-③						25.6			33.9		7.1	13.0				
RH10U-36①4R-②-③	11.4	-2.8	21.5	29.7	15.6	25.6	13.6	10.4	55.9	7.87	8.7	33.5	6.7			
RH10U-52①3N-②-③						27.0			33.9		11.4	15.7				
RH10U-X5①3N-②-③	13.4	-4.7	19.5	30.1	15.9	27.0	13.6	12.0	55.9	9.84	15.7	33.5	13.8			
RH15U-26①4Q-②-③						33.9			55.9		7.1	13.0				
RH15U-36①4Q-②-③	13.4	-4.7	19.5	30.1	15.9	25.6	13.6	12.0	55.9	9.84	8.7	33.5	13.8			
RH20U-26①3Q-②-③						33.9			55.9		7.1	13.0				
RH20U-36①3Q-②-③	13.4	-4.7	19.5	30.1	15.9	25.6	13.6	12.0	55.9	9.84	8.7	33.5	13.8			

*15 and 20 Ton models are equipped with 2 trolley motors.

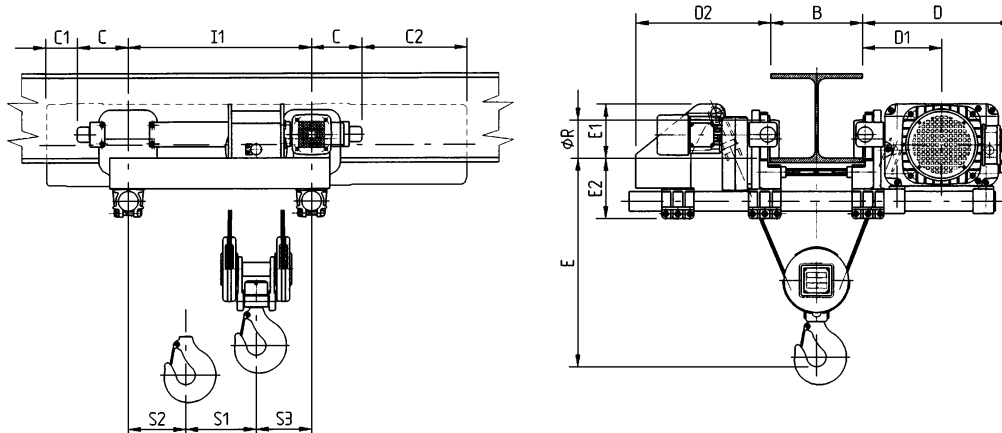

Note: ■ Standard headroom trolleys are suitable for use on S or W shaped beams.